

EML921/42

Emulator of Mercedes Benz passenger seat occupation sensor

Compatible with MB models: E class W211 with "Temic" SRS control unit

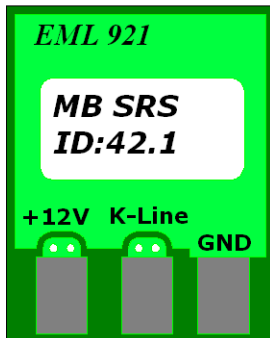

+12V - Power supply
K-Line - data line
GND - Ground

MB SRS (Airbag) system, passenger seat occupation emulator works with MB E class W211 (Temic control unit)
Emulator used to replace broken original seat occupation sensor.

When emulator installed, in case car crash, passenger airbag will trigger, with or without passenger on the front seat.

**After installing emulator,
DO NOT set a child with children's seats in the
front passenger seat !**

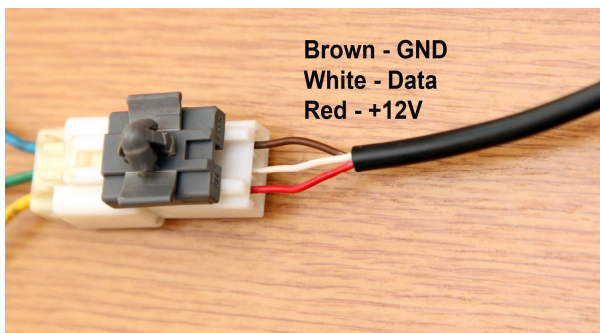

Occupation control unit placed inside passenger seat. Black cable from unit connected with car wiring installation (white connector as shown in photo, placed under the passenger seat).

Wire colors inside cable – all times the same:

Red: +12V
White: Data
Brown: GND

After connector (in car side) wiring colors different in different models

