

**EML922/US.5**  
**Universal SRS seat occupation sensor emulator**  
 Manual edition 2 (2016.03.09)

*Used in cars: BMW, MB, Fiat, Mazda*

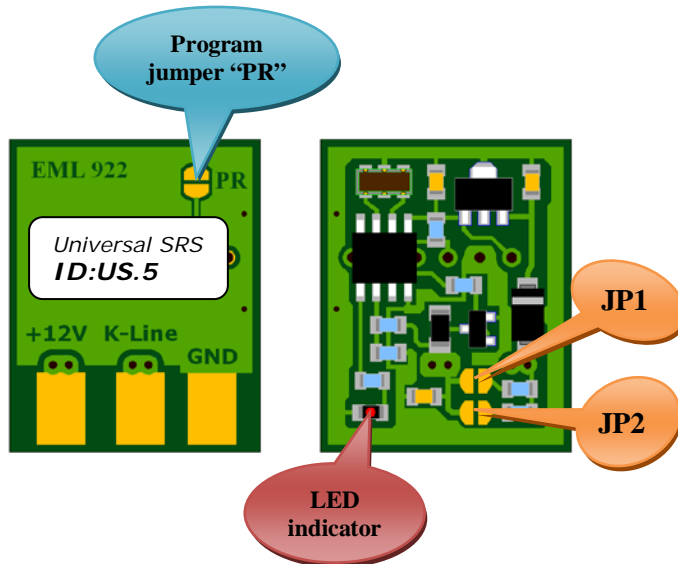

**EML922/US.5 wire terminals description:**

[+12V] - power supply

[K-Line] - Data wire, connected to SRS ECU

[GND] - Ground.

**Emulator can be programmed in two ways:**





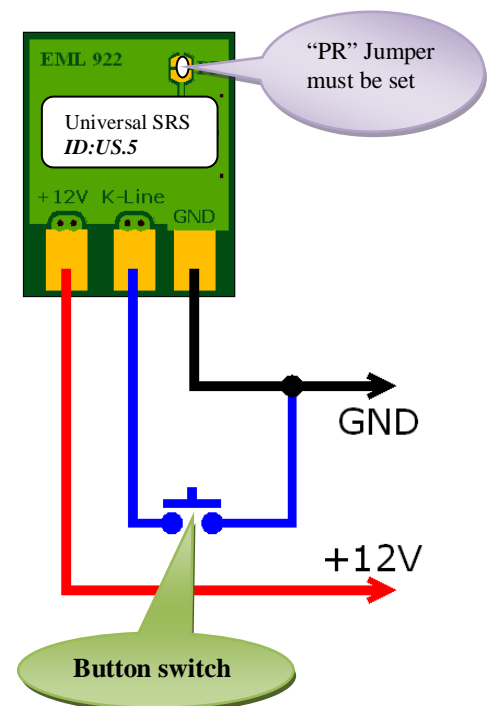







*The first way – manual (with push button):*

1. Set program jumper “PR” (See picture at the right).
2. Set pull up jumper “JP1” or “JP2. (Minimum one pull up jumper must be set. No matters which.)
3. Connect push button, and prepare power supply connection as shown in picture at the right.
4. Press and hold push button.
5. Switch power supply keeping button depressed.
6. LED indicator go on and after 2 sec. goes out.
7. When LED goes out – release the button. (If button will be released before LED extinguish, LED blink five times per second and emulator gone to PC programming mode. In this case repeat procedure from step 3).
8. After 2 sec LED blink number of times equivalent current program number (see table below).
9. When LED goes out, within 5 sec start enter new program number.
10. To enter new program, press button as many times as is the number of new program. (Each button press indicates with LED).
11. After entering new program, LED blink number of times equivalent new program number (count and check blinks according table below)
12. After new program indication LED start fast blink (5 times per second), it's no limited time to switch off power supply.
13. Manual programming finish. If not correct new program number (check in step 9 not ok), repeat programming from step 3.
14. Remove program jumper “PR”.



**After programming set or remove jumpers JP1 and JP2 according new program (see table below)**

**Emulator program table:**

Program number	Used in vehicles	Occupation status	Jumper JP1 and JP2 setting
1 <i>Factory set</i>	BMW E38, E39, E46, E60/61 (2003-2006)	Occupied	
2	Mazda all models from 1998 until 2006	Occupied	
3	MB from 1998 until 2000	Occupied	
4	MB from 1999 until 2005 (except E class W211)	Occupied	
5	MB E class W211 (Temic SRS unit)	Occupied	
6	Fiat Stilo	Occupied	
7	BMW E38, E39, E46, E60/61 (2003-2006)	Not occupied	
8	Mazda all models from 1998 until 2006	Not occupied	
9	MB from 1998 until 2000	Not occupied	
10	MB from 1999 until 2005 (except E class W211)	Not occupied	
11	MB E class W211 (Temic SRS unit)	Not occupied	
12	Fiat Stilo	Not occupied	

**After installation emulator:**

**DO NOT place the children with children's seat on the front passenger seat!  
SRS system not recognize children's seat, and passenger airbag still active!**

*Second way of programming (with PC software) will be explained in third manual edition.*